

**HIGH EAVE (SCULPTURED)**

FH2010 - HIGH EAVE DETAIL WALL PANELS

FH2612 - HIGH EAVE DETAIL W INSULATED WALL PANELS

## FH2010 - HIGH EAVE DETAIL WALL PANELS

[Download the DWG file by clicking here.](#)

### HIGH EAVE LAP & FLASHING BACKER

SLIDE FIELD CUT SECTION FLASHING ENDLAP BACKER ONTO THE LOWER TRIM PIECE. PLACE TAPE MASTIC NEXT TO HEM OF THE BACKER (NOT ON TOP OF HEM). APPLY CONTINUOUS BEAD OF CAULK 1" FROM END OF TRIM DOWN PROFILE OF TRIM. FASTEN LAP WITH STITCH FASTENERS AND POP RIVETS AS SHOWN.

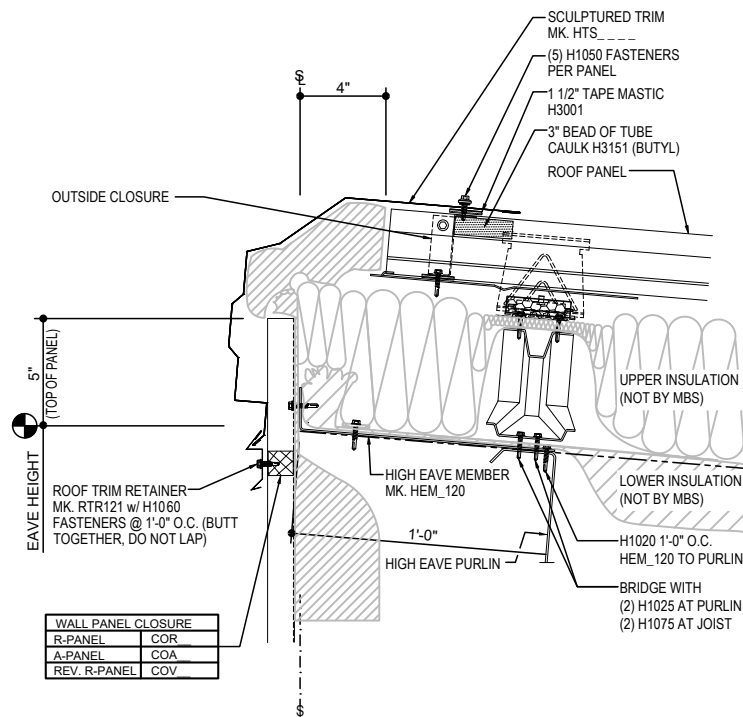
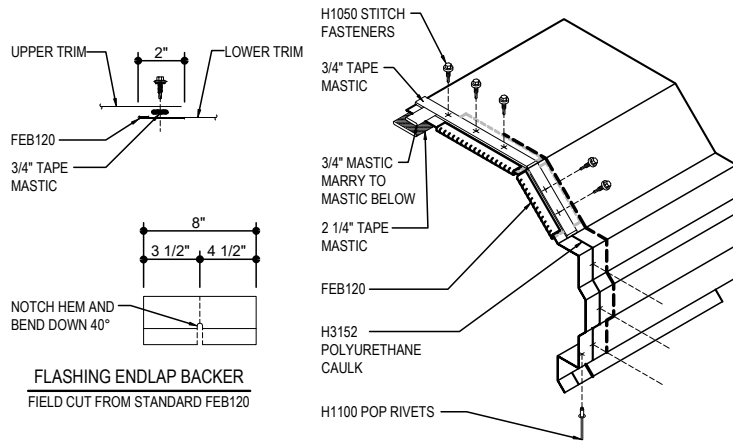

### R-Boost™ HIGH EAVE SCULPTURED DETAIL

HIGH EAVE SCULPTURED DETAIL w/ WALL PANELS  
SEE WALL SHEETING ERECTION NOTES FOR WALL PANEL FASTENER LOCATIONS

**FH2010**

#### Detailer Notes:

- 1) CLOSURE LAYER IS ON BY DEFAULT.  
CLOSURE LAYER MUST BE TURNED OFF IF CLOSURES ARE NOT REQUIRED.

## FH2612 - HIGH EAVE DETAIL W/ INSULATED WALL PANELS

[Download the DWG file by clicking here.](#)

### HIGH EAVE LAP & FLASHING BACKER

SLIDE FIELD CUT SECTION FLASHING ENDLAP BACKER ONTO THE LOWER TRIM PIECE. PLACE TAPE MASTIC NEXT TO HEM OF THE BACKER (NOT ON TOP OF HEM). APPLY CONTINUOUS BEAD OF CAULK 1" FROM END OF TRIM DOWN PROFILE OF TRIM. FASTEN LAP WITH STITCH FASTENERS AND POP RIVETS AS SHOWN.

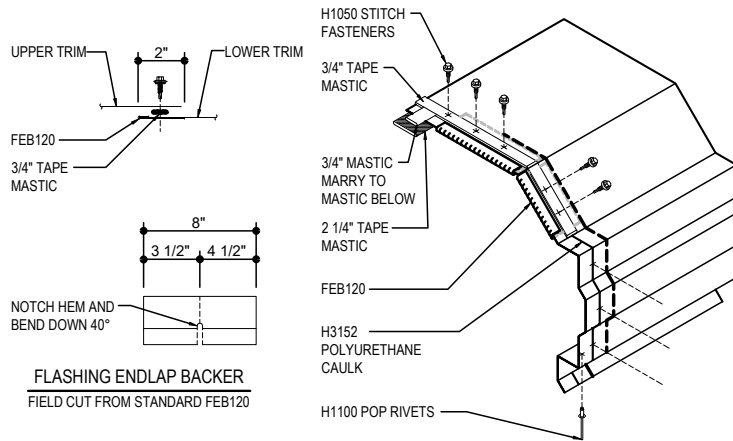

**FLASHING ENDLAP BACKER**  
FIELD CUT FROM STANDARD FEB120

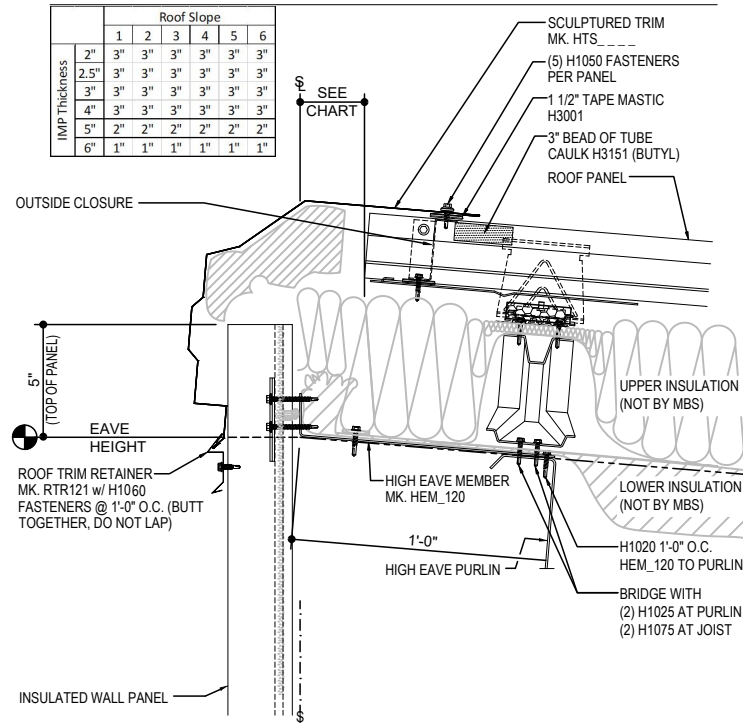

**R-Boost™ HIGH EAVE SCULPTURED DETAIL**  
HIGH EAVE SCULPTURED DETAIL w/ INSULATED WALL PANELS

**FH2612**

### Detailer Notes:

- 1) N/A